

SOHNNE®

ASSEMBLY INSTRUCTION

Haller Series



Welcome Guide

www.sohnne.com

In the Box

Lay out every component and tool before you begin. Quantities vary by configuration — check each part against your packing list.

COMPONENTS

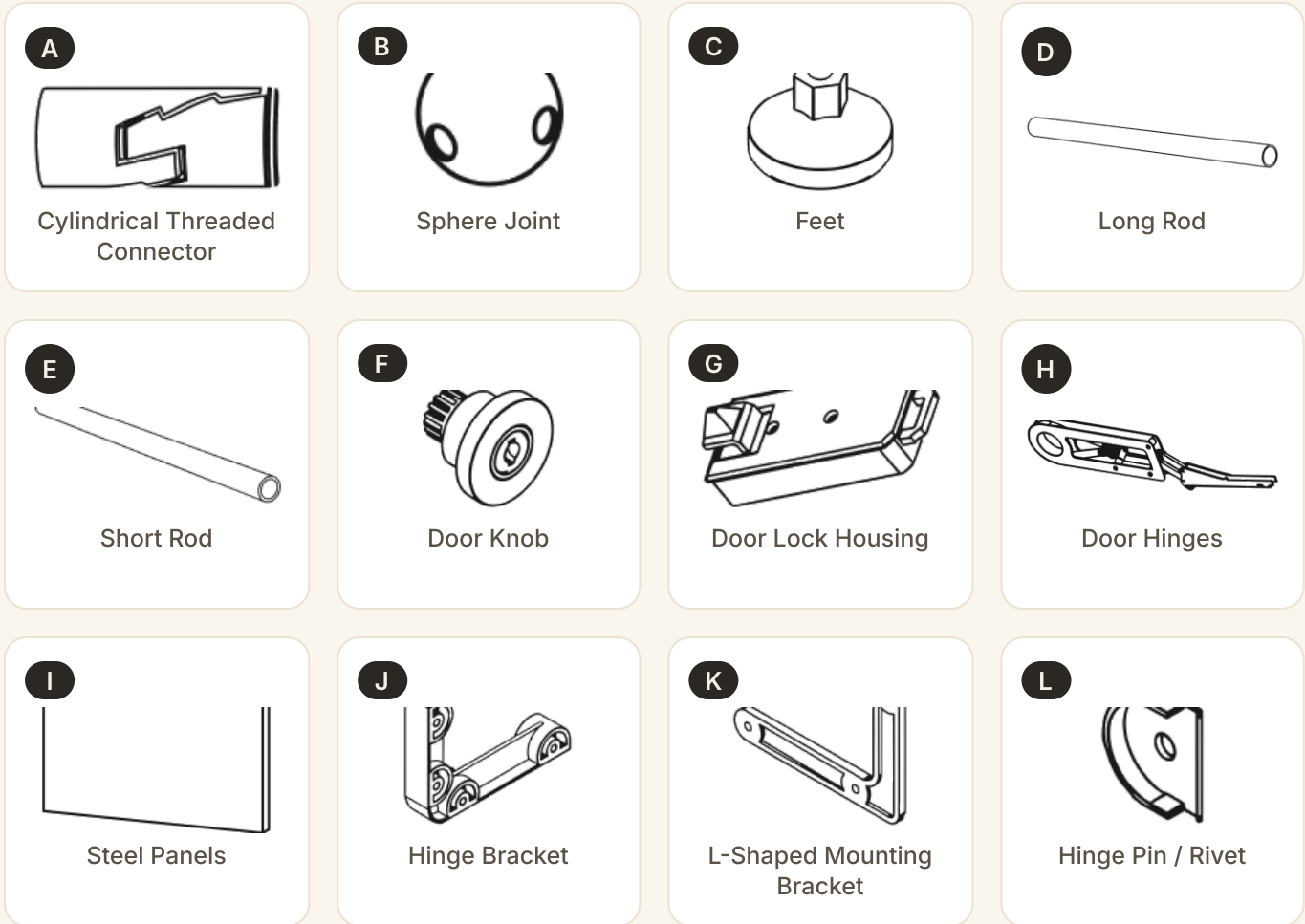

HARDWARE & TOOLS

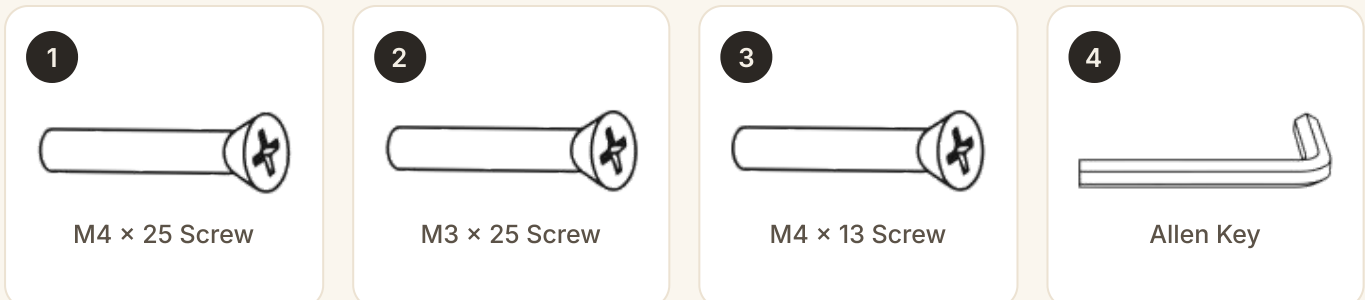

1 Connect the joints

Insert a cylindrical threaded connector (A) into each port of the sphere joints (B). Tighten lightly with the Allen key (4) — but do not fully tighten yet. Keep every joint loose so the frame can be squared up once it is fully assembled.

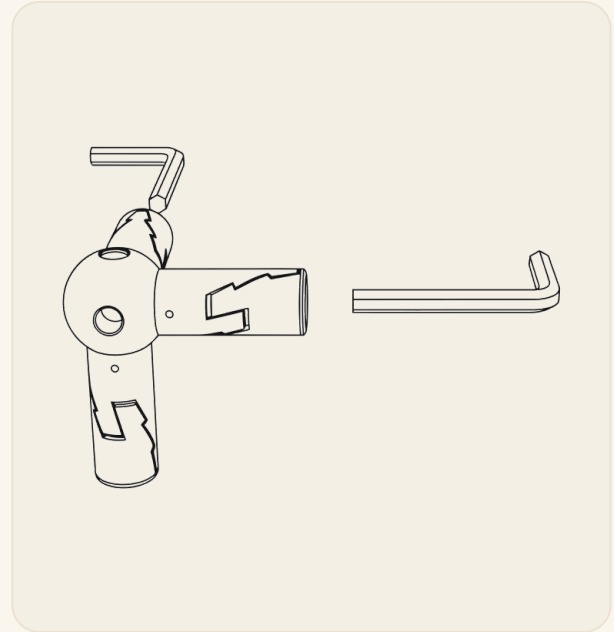

2 Add the short rods

Fit a short rod (E) between two sphere joints, seating it firmly at both ends. Tighten the connector at each end just enough to hold. Aim for a flush, seamless connection.

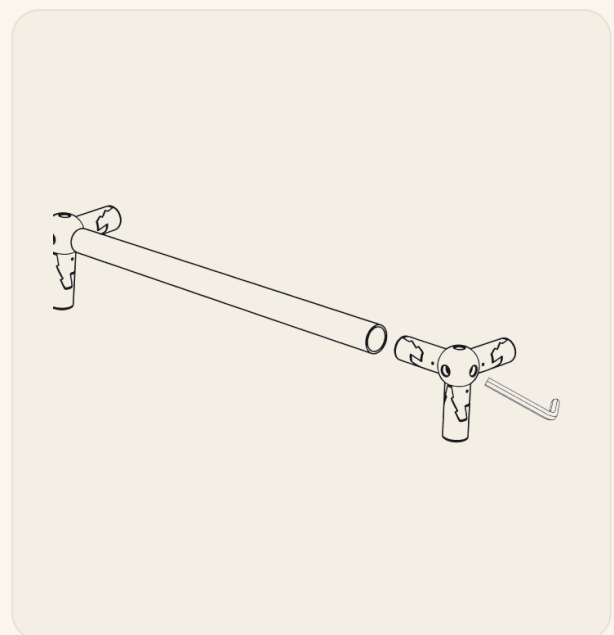

3 Extend with long rods

Connect the long rods (D) to the sphere joints to extend the frame outward, using the Allen key (4) for better torque. Continue until the frame closes into a complete rectangle — keeping all joints loose.

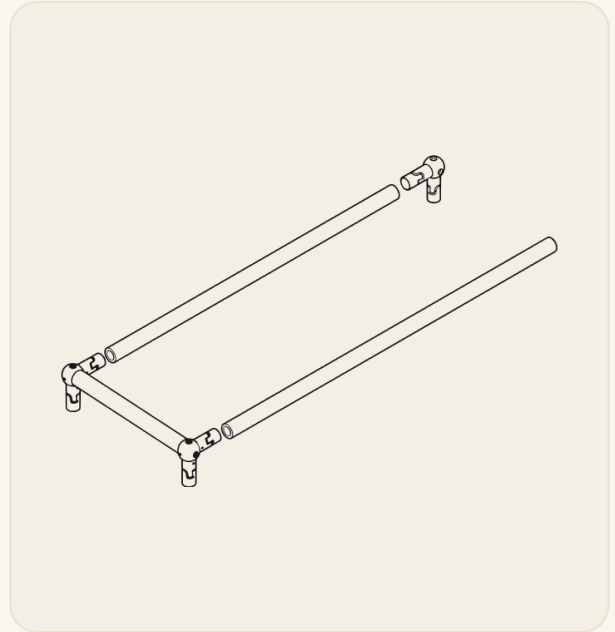

4 Attach the feet

Screw a foot (C) into each bottom sphere joint. Every foot has a flat rubber base and a threaded bolt stem, so you can fine-tune the height to level the unit on uneven floors.

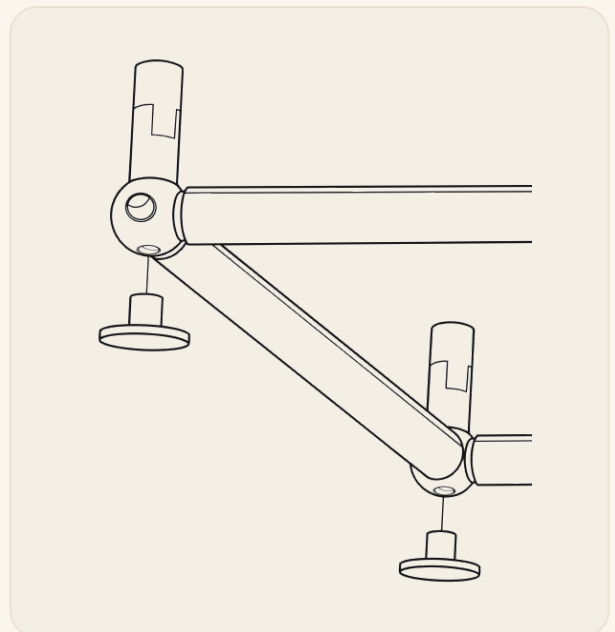

5 Prepare the door panels

Attach the hinge parts to the side panels. Position the L-brackets (K) at the panel corners and pass the hinge pins (L) through the hinge brackets (J). Clamp the door hinges (H) around the vertical rod and secure with M4 × 25 screws (1), tightening in a cross pattern to avoid warping.

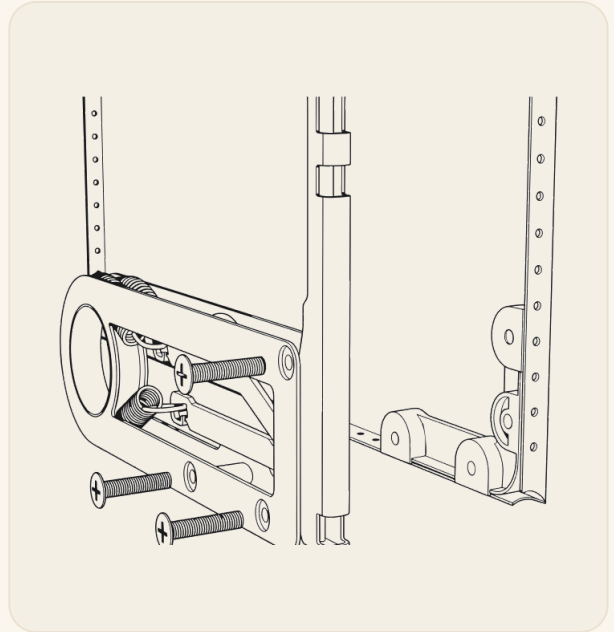

6 Hang the panels

Insert the steel panels (I) into the frame, pivoting them into position on the hinges. Close both panels so they sit fully flush with the frame.

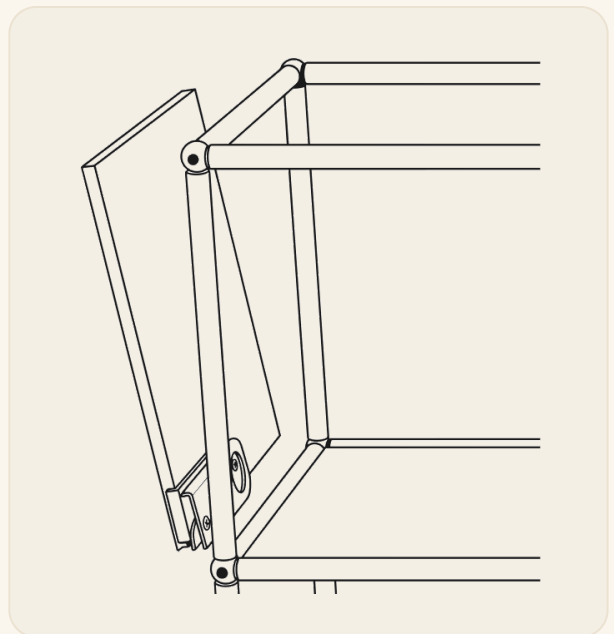

7 Build the lock

Insert the spring-loaded clamp into the door lock housing (G). The clamp grips the horizontal rod when the door is closed. Clip the assembled lock unit onto the top-centre edge of each door panel.

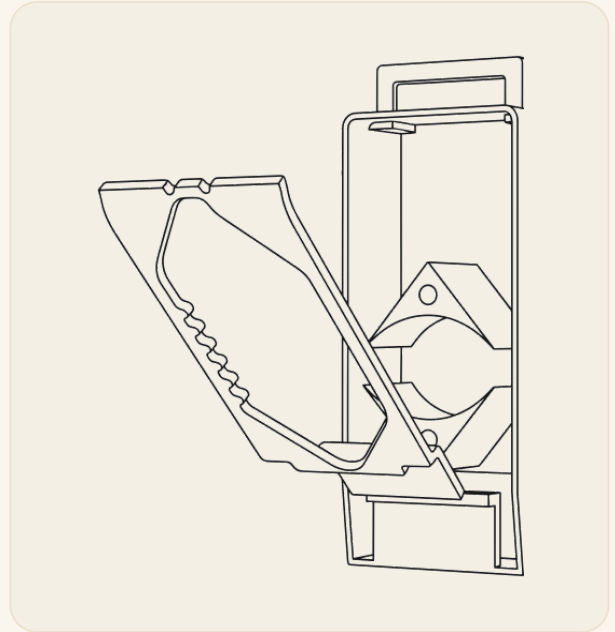

8 Fit the door knob

Push the door knob (F) through the pre-drilled hole on the front face of the door panel and tighten using the flat-head slot with a screwdriver. Turning the knob engages or disengages the spring latch.

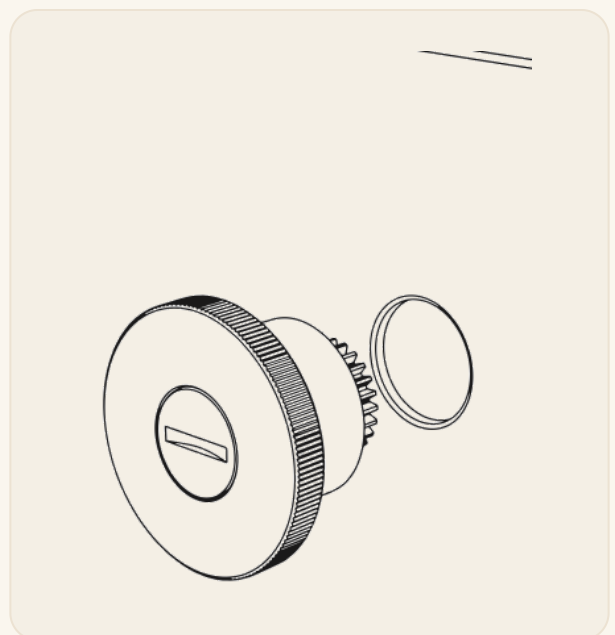

9 Secure the lock

From the back of the door panel, fix the lock housing (G) permanently in place using the M3 × 25 screws (2).

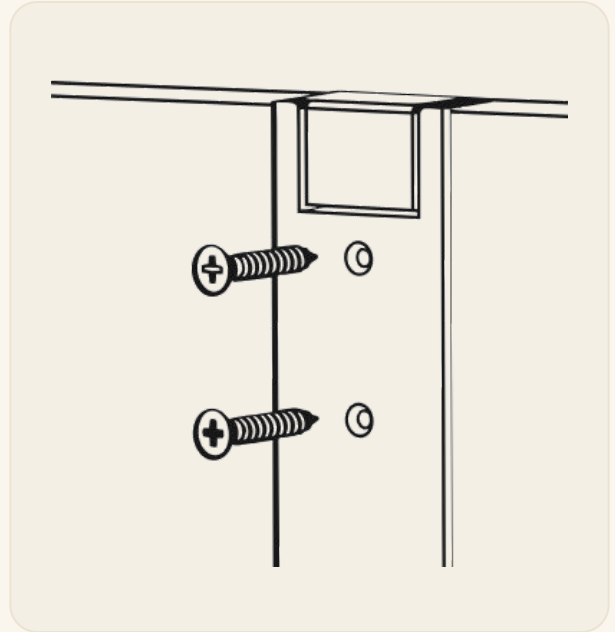

10 Final check

Confirm both doors sit at the same height. They should swing freely and close flush with the frame, with an audible click as the latch engages.

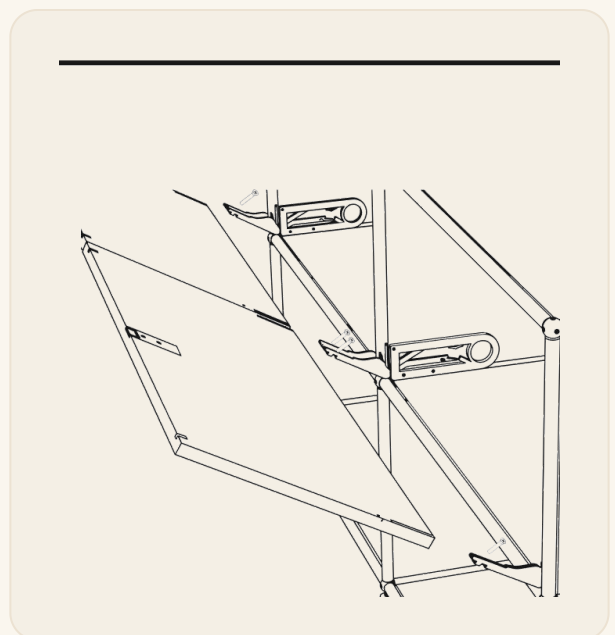

SOHNNE®

@sohnne

SHARE · REVIEW · EARN

Worth sharing.

\$100

FOR A VIDEO REVIEW

\$50

FOR A PHOTO REVIEW

 Tag us @sohnne

www.sohnne.com